

A thick green vertical bar runs down the left side of the page. A green arrow points to the right from the bar, containing the date 2022.09.20.

2022.09.20

Specification

of Tower Combiner Box

1. Product introduction

1.1 Product introduction

Tower Combiner Box in the energy storage system is to ensure that the energy storage component orderly connection and the connection device of flow function. Combiner Box can guarantee energy storage system is easy to cut off the circuit when maintenance, inspection, failure occurs when the energy storage system, reduce the scope of the power outage ensure availability of system.

1.2 Product introduction

Item		UNit	SPEC
PCS Voltage	Maximum	Vd.c	150~700
Battery Voltage	Maximum	Vd.c	168~657
PCS Current	Rated	A	104
Battery Current	Rated	A	104
Power supply rated supply voltage		V	24VDC/220VAC
Maximum number of battery clusters supported			12
Dimenson(W*D*H)		MM	500*450*150
Weight		KG	15
IP Rating			IP20
Altitude		m	4000
Operating Temperature		°C	-40~60

2. Basic principles and structures

2.1 working principle block diagram

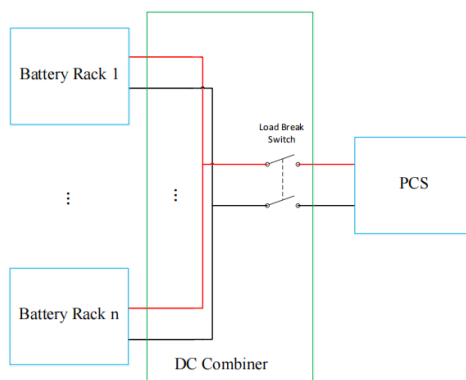

Working principle block diagram

2.2 working principle

The bus box is mainly composed of bus copper bars, switches and boxes. When the switch is closed, the electric cabinet of each branch passes through the copper confluence .

The row is connected to the PCS to realize the energy interaction between the cabinet and the PCS. When the switch is turned off, the energy storage system can be maintained.

2.3 appearance and structure

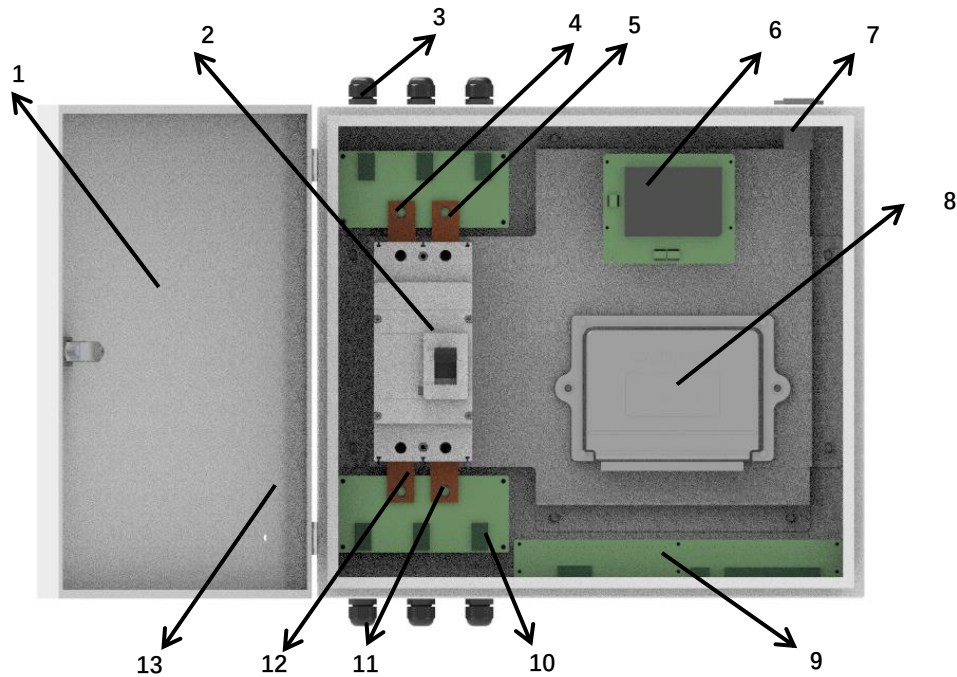

Item	Name	Definition
1	box	Tower combiner box
2	switch	When working normally, close the disconnecting switch; Turn off the disconnecter when maintaining the device
3	water joint	The battery and inverter power cables are routed from here
4	Positive port of PCS	A maximum of three cables can be connected
5	Negative port of PCS	A maximum of three cables can be connected
6	AC/DC	Convert 220VAC to 24VDC to supply power to BMS
7	AC input	Connected to 220VAC power supply to supply power to BMS
8	BMS	The master BMS is used to summarize the battery data of each cluster and communicate with the inverter
9	Multi-function Signal PCB	Integrate functions such as 24V power supply

		and communication conversion
10	DC terminal block	Power cable connection for battery and inverter, single maximum current supports 40A
11	Negative port of electrical box	Up to three electric box can be connected
12	Positive port of electrical box	Up to three electric box can be connected
13	Grounding interface	Connection for grounding cable

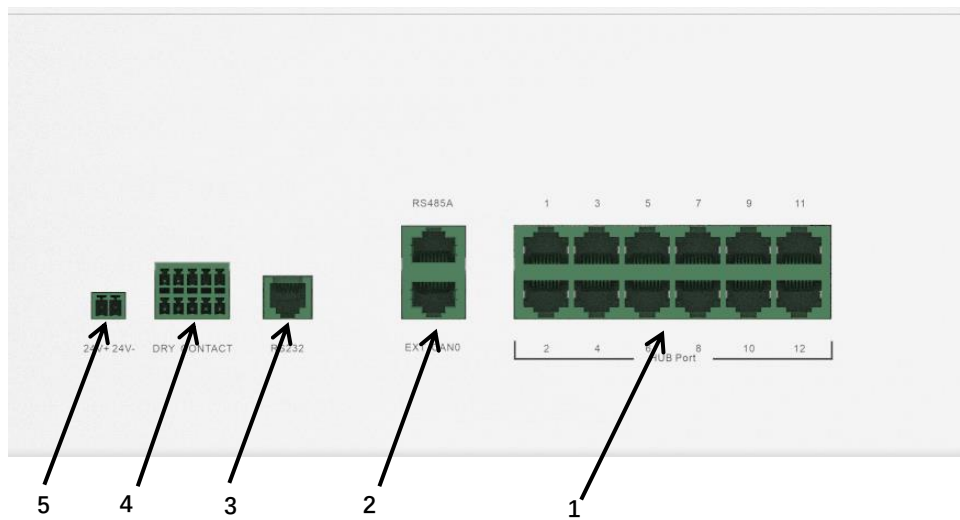

Item	Name	Definition
1	CAN RJ45	Connect the internal communication of each cluster of batteries
2	CAN/RS485 RJ45	Communication interface with external devices
3	RS232 RJ11	Communication interface with external devices
4	Dry Contact Socket	reserve
5	24V input	Connected to 24VDC power supply to supply power to BMS

2.4 Communication Port Definition

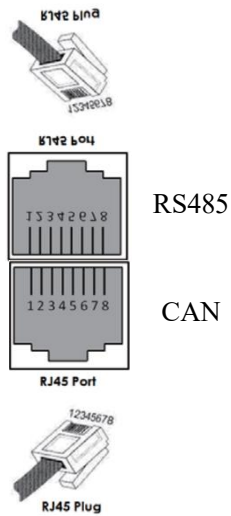

PIN (RS485)	Color	Definition
PIN1	Orange/white	485B
PIN2	Orange	485
PIN3	Green/white	XGND
PIN4	Blue	NC
PIN5	Blue/white	NC
PIN6	Green	NC
PIN7	Brown/white	NC
PIN8	Brown	NC
PIN (CAN)	Color	Definition
PIN1	Orange/white	NC
PIN2	Orange	NC
PIN3	Green/white	NC
PIN4	Blue	CANH
PIN5	Blue/white	CANL
PIN6	Green	NC
PIN7	Brown/white	NC
PIN8	Brown	NC

- (1) CAN cable should be pair of twisted line shielded Ground. Grounded by single point should be observed.
- (2) There is one 120Ω served as resistor as terminal load in displayer. If cancellation is needed, please notice it during ordering.



Jiangsu Daqin New Energy Tech Co., Ltd.
Address: 158# South Ji'an Road, Hi-Tech District,
Yangzhou City, Jiangsu Province, China,211400.
Email: Sales@dyness.net
Website: www.dyness-tech.com.cn